

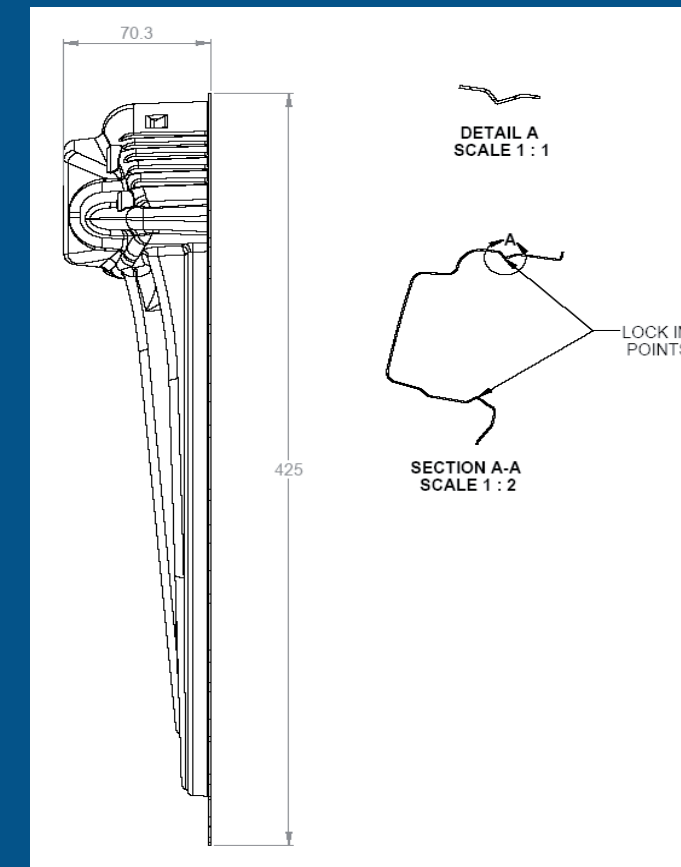

Australian Inhibitor

Proudly Protecting Australia's Local and Export Industries

HOLDEN HSV VCI Ferro-form™ ROTOR & CALIPER COVER



Co-extruded rigid plastic rotor and caliper cover

1. Lock onto caliper, special lugs
2. Road tested to 100 kph
3. With stand water, dirt, grit
4. Anti corrosion properties
5. Be removed from front of wheel

Rotor and caliper exposed surfaces

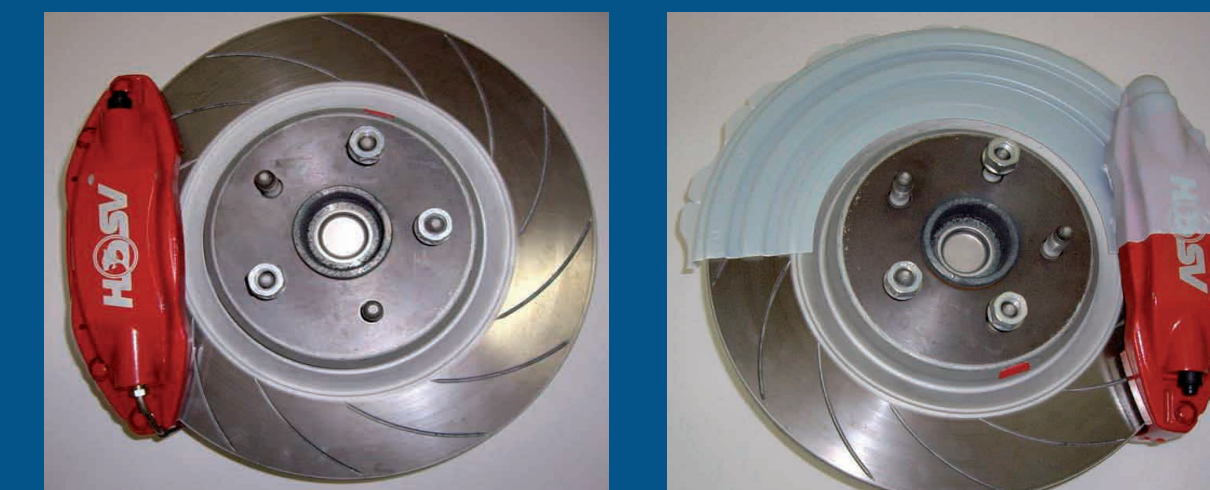

Rigid plastic cover protecting assembly



Research & Development
Laboratory Testing & Design

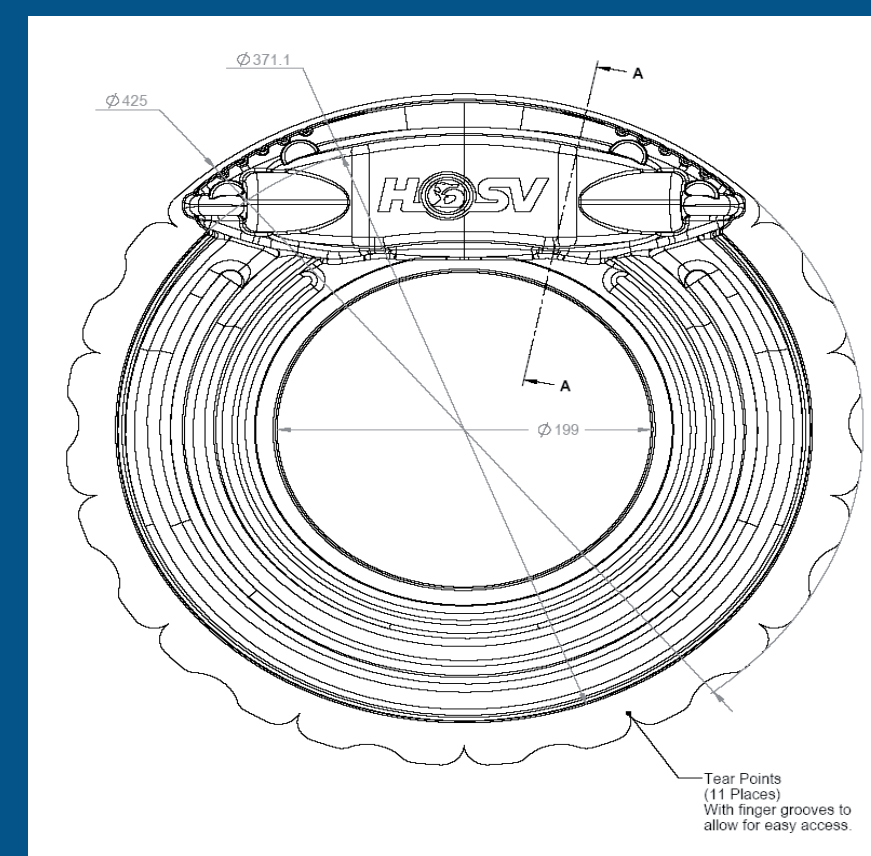

Design



Function - Trials

HSV Export Rigid Plastic
Product Created

New Export Product